



匯統國際股份有限公司

Huey Tung International Co., Ltd.

產品規格書

Specification

[Model : HTPA-1554 / 2013.1.29 version]



Cara Audio Corporation

No.69, Lane 762, Dingzhong Road, Sanmin District, Kaohsiung City, Taiwan, ROC.

Tel: 886-7-310 5786 / Fax: 886-7-310 0783

E-mail: carawang@hueytung.com.tw / <http://www.hueytung.com.tw>

揚聲器製品規格書 SPEAKER SPECIFICATION

型號 Model Number:HTPA-1554

項目 Items		規格 Specification			
1	公称阻抗 Nominal Impedance	4Ω±5% at 150 Hz 1.0v			
2	最低共振周波数 Lowest Resonance Frequency	28 Hz±20%Hz Without a baffle			
3	实效周波数带域 Effective Frequency Range	F0~5KHz -10dB			
4	出力音压 Output Sound Pressure Level	93dB±3dB 1W/1M at (400,600,800,1000)Hz AVE.			
5	入力 Input	定格入力 Rated input 100 W	最大入力 Maximum input 200 W		
6	磁束密度 Flux Density	-----±10% GAUSS			
7	异常音试验电压 Buzz & Rattle Test	Must be normal at sine wave 14.14 V			
8	动作试验电压 Operation Test	Must be normal at program source 20 V			
9	极性 Polarity	/			
10	磁石尺寸/重量 Magnet Dimension/Weigh	Magnet:156*80*20 Y30 Sub Magnet:	/G		
11	连续负荷试验 Life Test	DIN45573 noise 100 W 96 hours			
12	耐热试验 Heat Resistance	70°C±5°C 30%-35%RH 8Hours and then room temperature 1 hours			
13	耐湿试验 Humidity Resistance	40°C±2°C 90%-95%RH 8Hours and then room temperature 1 hours			
14	耐寒试验 Cold Resistance	-25°C±2°C 24Hours and then room temperature 1 hours			
15	落下试验 Drop Test	1M 75°±2°			
16	绝缘耐压试验 Insulation Resistance	Or more 1MΩ 以上			
17	周波数特性 Frequency Response Curve	参照附图 On Other Drawing			
18	失真率 Distortion	/			
19	各部 材质	Cone Paper	Red Selvage		
		Voice Coil	50 φ x4Ω ACCW		
		Cap	/		
20	总重量 Total Weight	/			
		Size: 15" 試作發行: 2009.08.19	Approve: Arthur	Check: John	Design: LIU

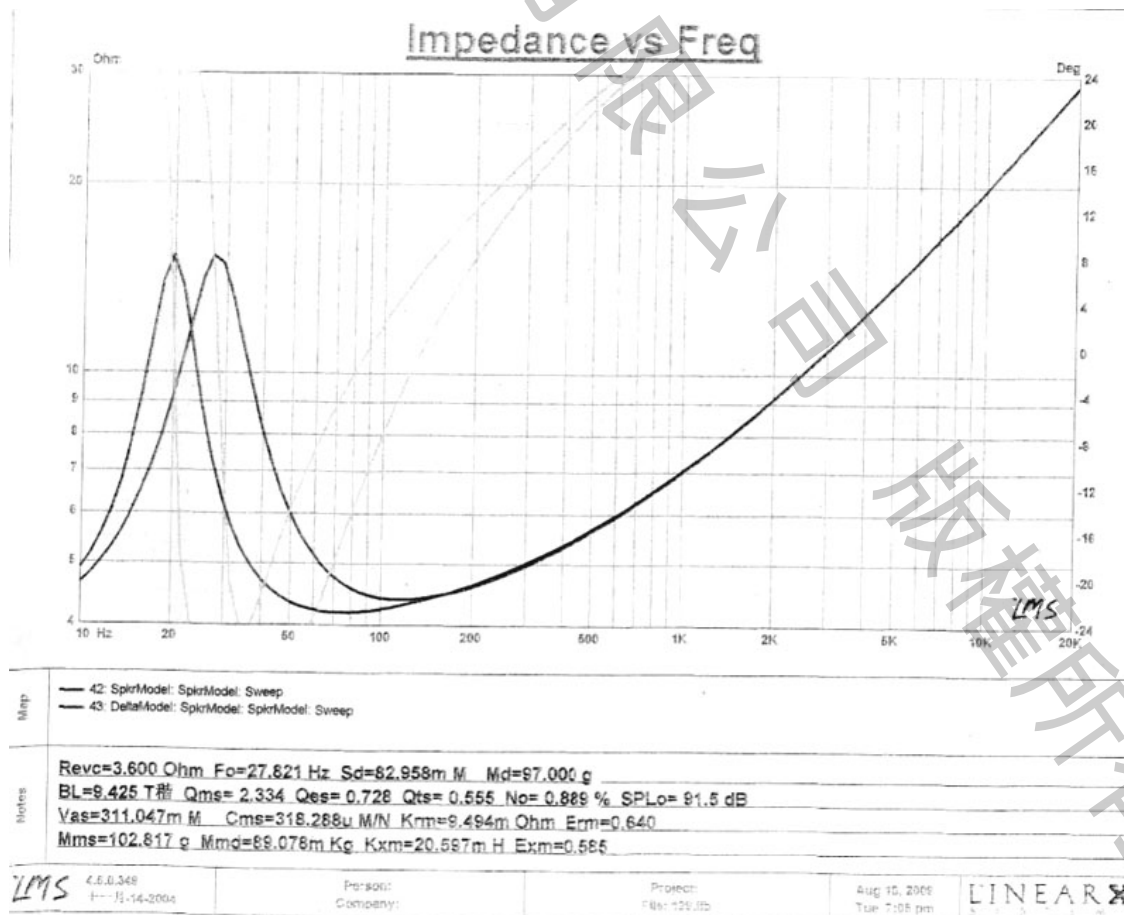
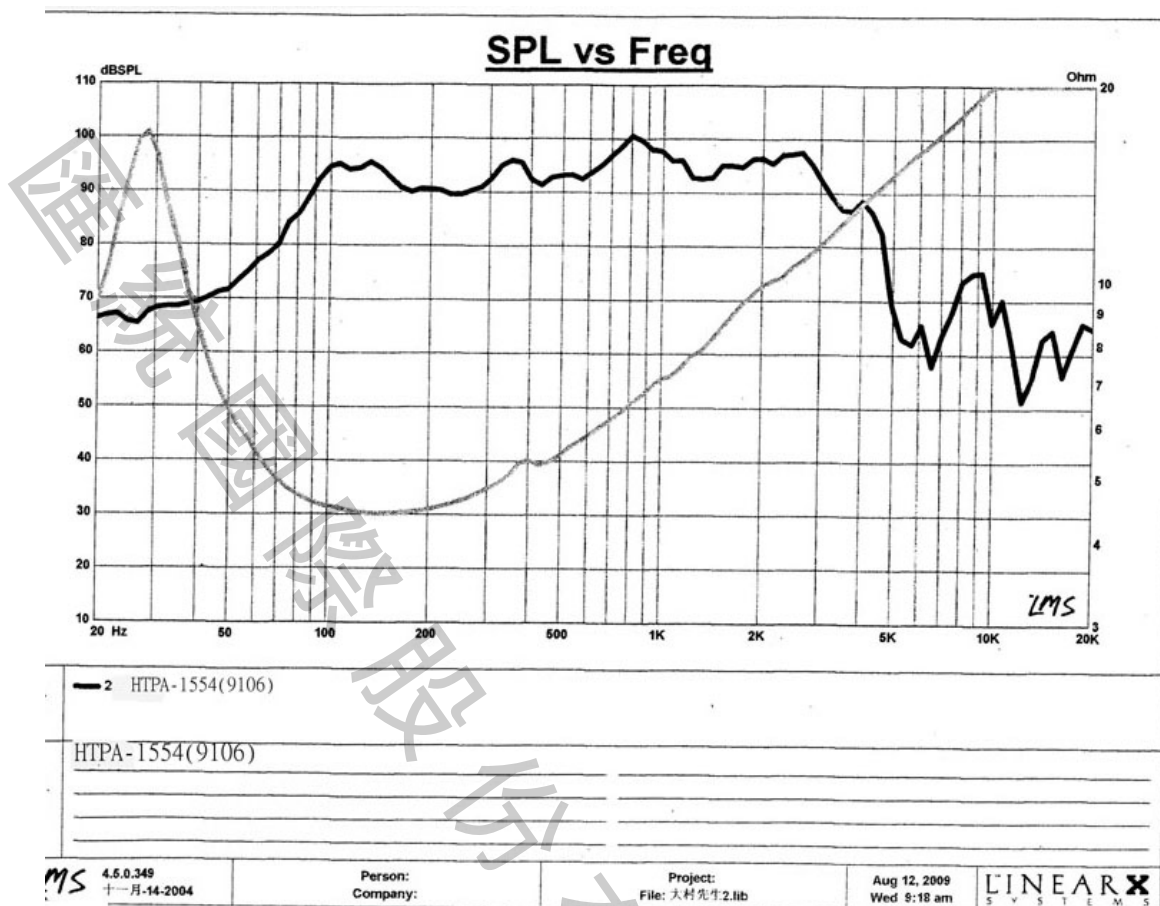

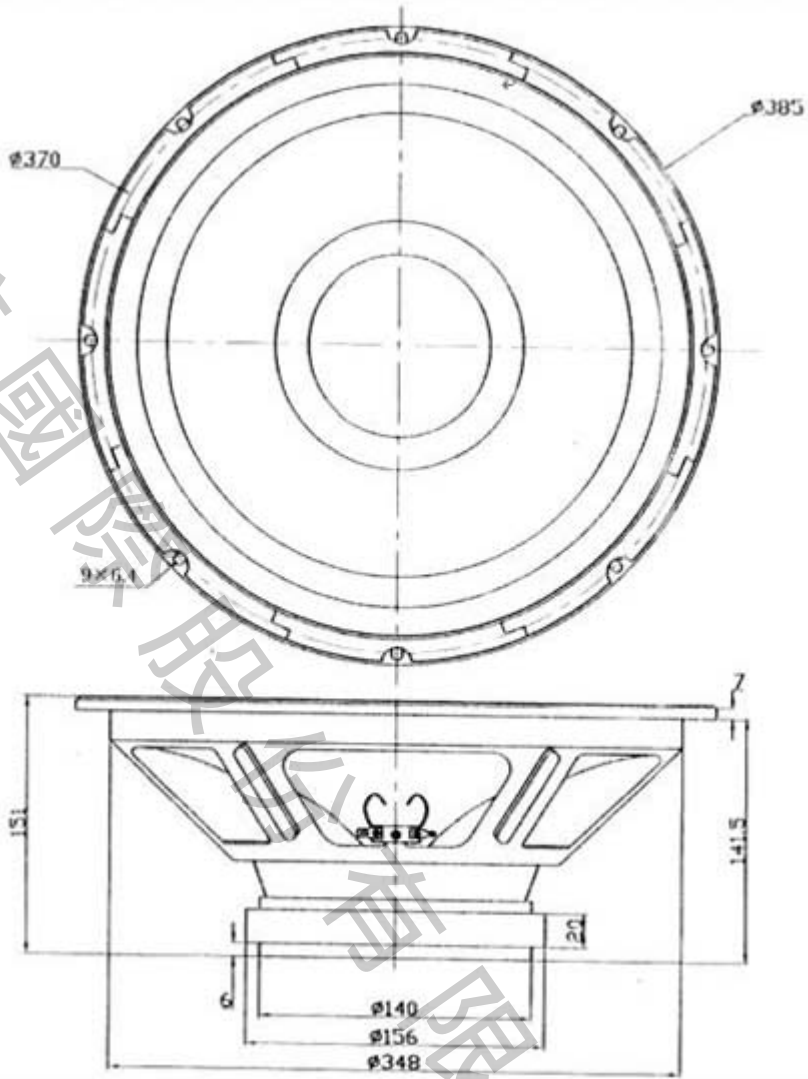

Tolerance: 0.2
Unit: mm