



匯統國際股份有限公司

Huey Tung International Co., Ltd.

產品規格書

Specification

[Model : HT-8380 / 2012.11.30 version]



Cara Audio Corporation

No.69, Lane 762, Dingzhong Road, Sanmin District, Kaohsiung City, Taiwan, ROC.

Tel: 886-7-310 5786 / Fax: 886-7-310 0783

E-mail: carawang@hueytung.com.tw / <http://www.hueytung.com.tw>

揚聲器製品規格書

SPEAKER SPECIFICATION

型號 Model Number: HT-8380 (70100)

項目 Items		規格 Specification		
1	公称阻抗 Nominal Impedance	4Ω±15%		
2	最低共振周波数 Lowest Resonance Frequency	1500 Hz±20%Hz Without a baffle		
3	实效周波数带域 Effective Frequency Range	F0~15KHz -10dB		
4	出力音压 Output Sound Pressure Level	80dB±3dB 1W/1M at (3K,5K,7K,9K)Hz AVE.		
5	入力 Input	定格入力 Rated input 10 W	最大入力 Maximum input 20 W	
6	磁束密度 Flux Density	-----±10% GAUSS		
7	异常音试验电压 Buzz & Rattle Test	Must be normal at sine wave 4.47 V		
8	动作试验电压 Operation Test	Must be normal at program source		
9	极性 Polarity	/		
10	磁石尺寸/重量 Magnet Dimension/Weigh	Magnet:36*18*6 Y30 Sub Magnet:	/G	
11	连续负荷试验 Life Test	Din45573 noise 10 W 96 hours	After the Test, Speaker should be meet the Outside and item 7,8	
12	耐热试验 Heat Resistance	70℃±2℃ 30%-35%RH 8Hours and then room temperature 1 hours		
13	耐湿试验 Humidity Resistance	40℃±2℃ 90%-95%RH 8Hours and then room temperature 1 hours		
14	耐寒试验 Cold Resistance	/		
15	落下试验 Drop Test	1M 75°±2°		
16	绝缘耐压试验 Insulation Resistance	Or more 1MΩ 以上		
17	周波数特性 Frequency Response Curve	参照附图 On Other Drawing		
18	失真率 Distortion	/		
19	各部 材质	Cone Paper	Titanium PEI	
		Voice Coil	/	
		Cap	/	
20	总重量 Total Weight	/		
	Size: 144*69	Approve:	Check:	Design:
	試作發行: 2010.08.12	Arthur	Tang	LIU

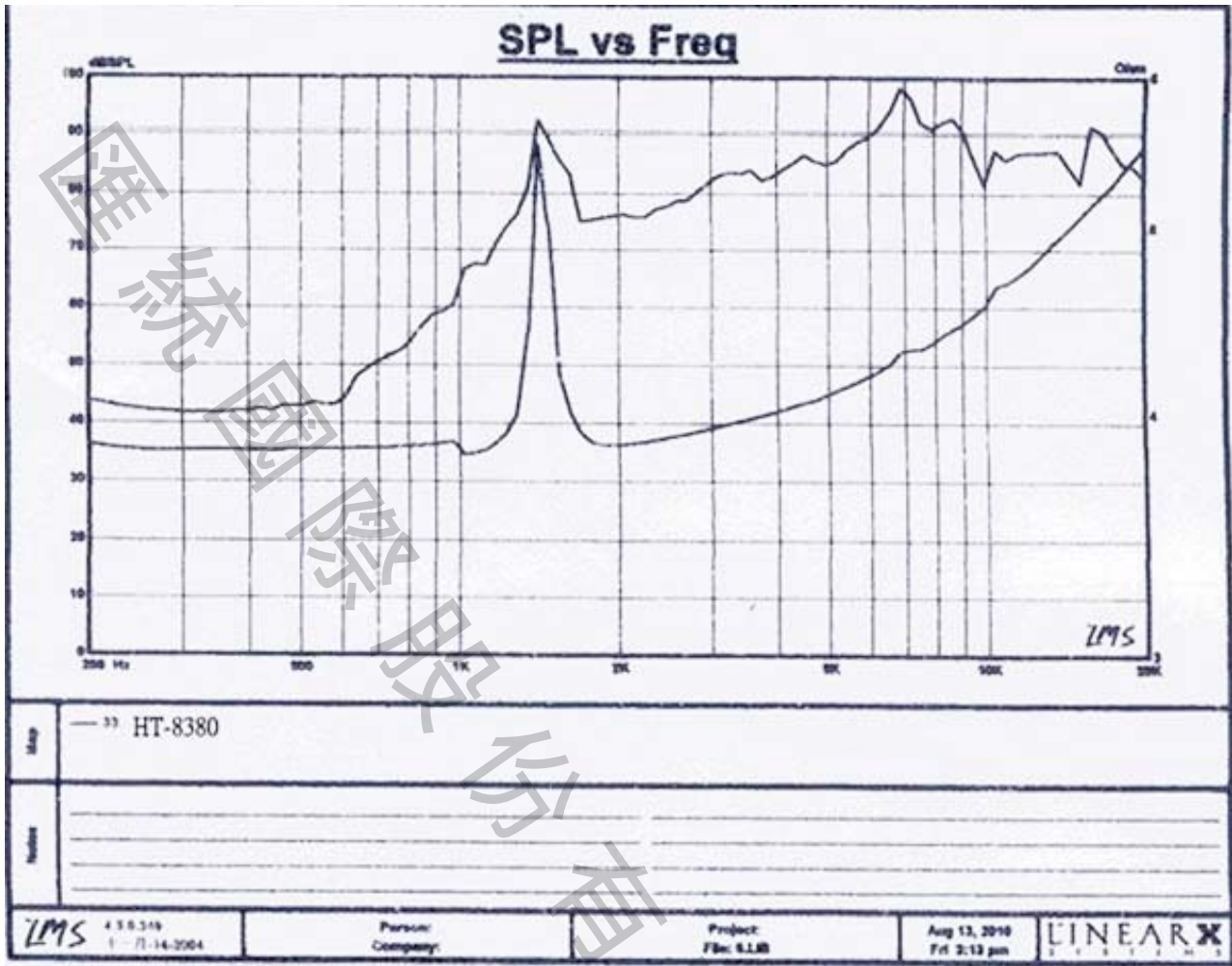

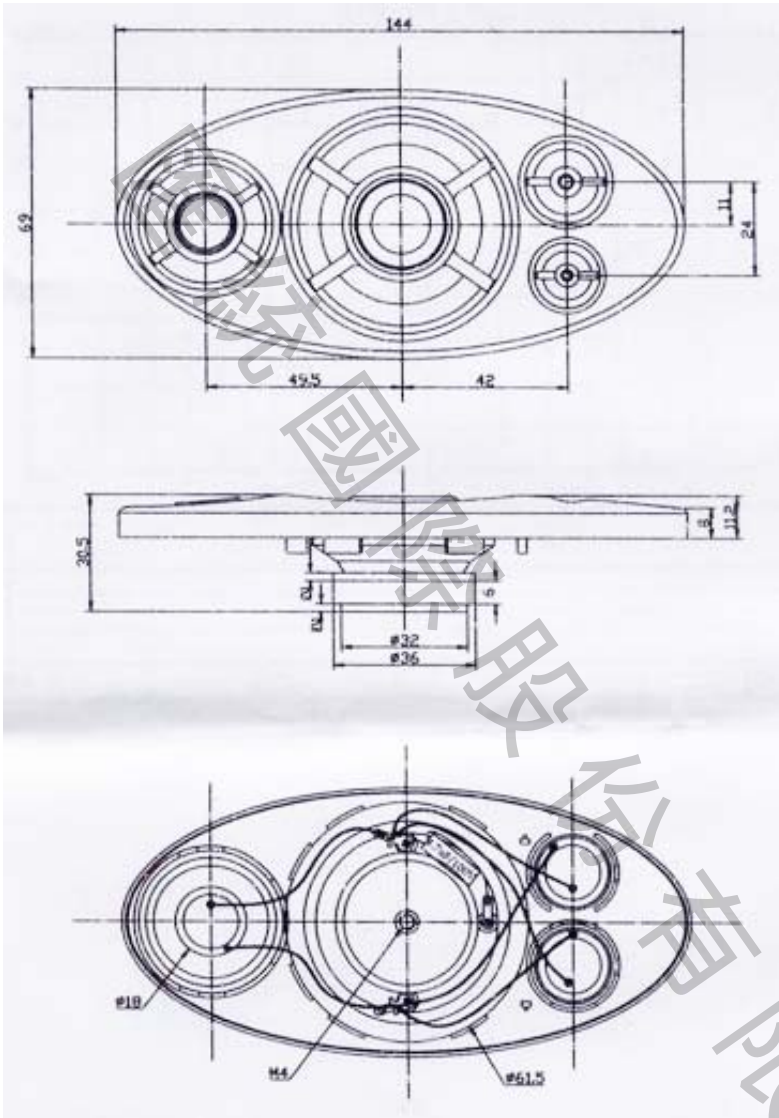

Toerance: ± 0.5

Unit:mm