



匯統國際股份有限公司

Huey Tung International Co.,Ltd.

產品規格書

Specification

[Model : HT-6352 / 2012.11.6 version]



Cara Audio Corporation

No.69, Lane 762, Dingzhong Road, Sanmin District, Kaohsiung City, Taiwan, ROC.

Tel: 886-7-310 5786 / Fax: 886-7-310 0783

E-mail: carawang@hueytung.com.tw / <http://www.hueytung.com.tw>

揚聲器製品規格書

SPEAKER SPECIFICATION

型號 Model Number: HT-6352

項目 Items		規格 Specification	
1	公称阻抗 Nominal Impedance	6Ω±15% at 180 Hz 1.0v	
2	最低共振周波数 Lowest Resonance Frequency	50 Hz±20%Hz Without a baffle	
3	实效周波数带域 Effective Frequency Range	F0~7KHz -10dB	
4	出力音压 Output Sound Pressure Level	80dB±3dB 1W/1M at (200,400,600,800)Hz AVE.	
5	入力 Input	定格入力 Rated input 30 W	最大入力 Maximum input 50 W
6	磁束密度 Flux Density	-----±10% GAUSS	
7	异常音试验电压 Buzz & Rattle Test	Must be normal at sine wave 13.4 V	
8	动作试验电压 Operation Test	Must be normal at program source	
9	极性 Polarity	/	
10	磁石尺寸/重量 Magnet Dimension/Weigh	Magnet:100*45*18 Sub Magnet:	/G
11	连续负荷试验 Life Test	DIN45573 noise 30 W 96 hours	After the Test, Speaker should be meet the Outside and item 7,8
12	耐热试验 Heat Resistance	55°C±5°C 20%-25%RH 8Hours and then room temperature 1 hours	
13	耐湿试验 Humidity Resistance	40°C±2°C 90%-95%RH 8Hours and then room temperature 1 hours	
14	耐寒试验 Cold Resistance		
15	落下试验 Drop Test	1M 75°±2°	
16	绝缘耐压试验 Insulation Resistance	Or more 1MΩ 以上	
17	周波数特性 Frequency Response Curve	参照附图 On Other Drawing	
18	失真率 Distortion	/	
19	各部 材质	Cone Paper	Rubber Edge+Black glass fiber cone
		Voice Coil	30Φx6Ω ASV 60度
		Cap	Black glass fiber
20	总重量 Total Weight	/	
	Size: 6.5"	Approve:	Check:
	試作發行: 2012.09.10	Arthur	LI
			Design: LIU

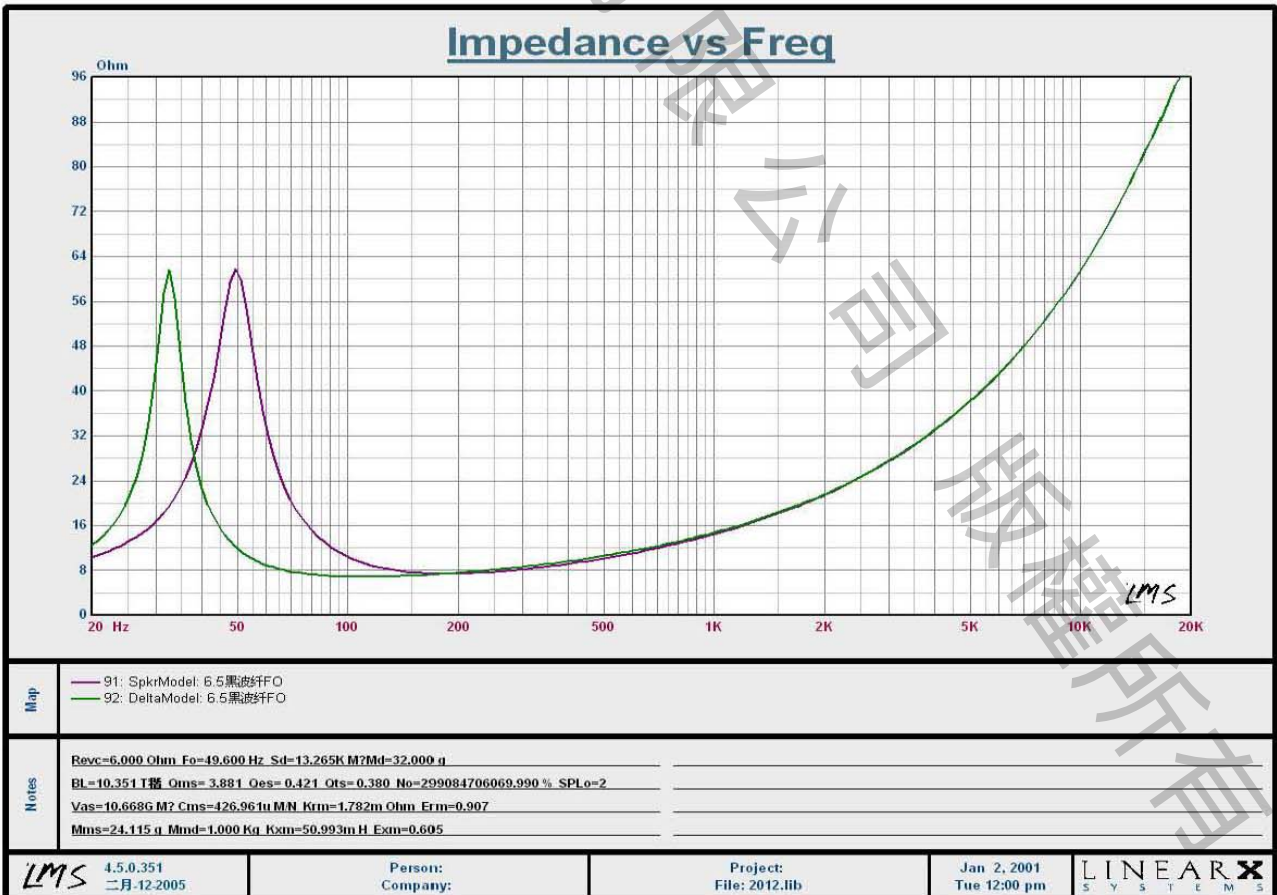

成品圖及照片 Mechanical Dimensions : HT-6352

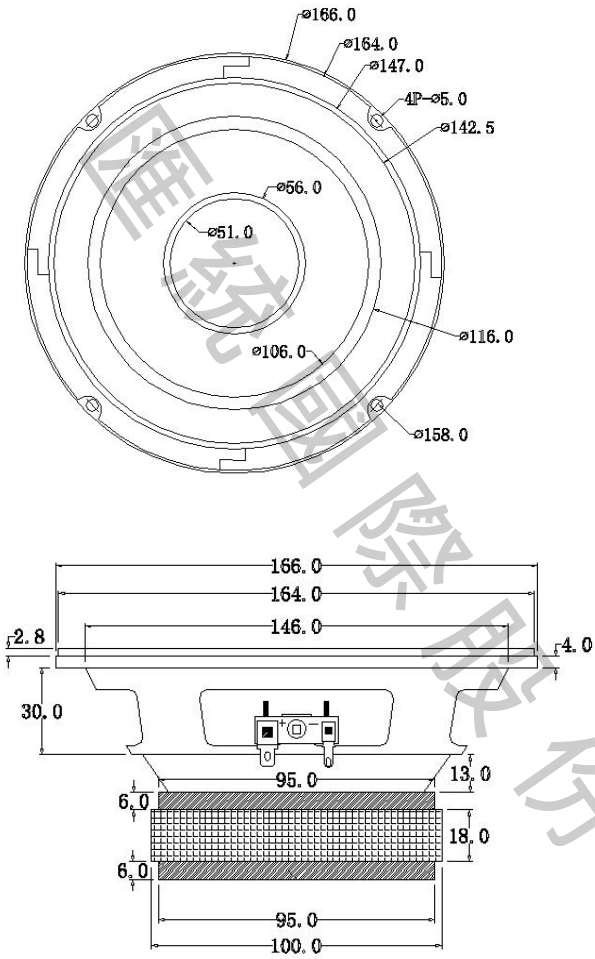

Tolerance: ± 0.5

Unit: mm